

IP 67

E 40

Type	Light source	Light source power	Lampholder type	Weight
STP 76 - 2400	sodium or metal-halide lamp	2 x 250 W or 2 x 400 W	E 40	11,8 kg

**Application**  
decks, holds, industrial areas, etc.

**Approvals**  
according to the rules of relevant classification societies, additional IEC

**Housing**  
stainless steel seamless deep drawn, powder coated white

**Diffuser**  
safety glass

**Reflector**  
aluminium anodized

**Lamps (not included)**  
high pressure sodium (HPS) lamp, metal halide (MH) lamp 250W/400W

**Electric**  
230V, flexible wiring, high temperature resistant

**Cable entry**  
junction box, 2 cable glands brass, M24x1.5, with earthing insert

**Mounting**  
adjustable bracket, stainless steel, 4 mounting holes,  $\varnothing 14$  mm

**Electrical connection**  
see finish section

**Remark**  
ballast unit VGP 76 - . . . has to be ordered separately

1.05

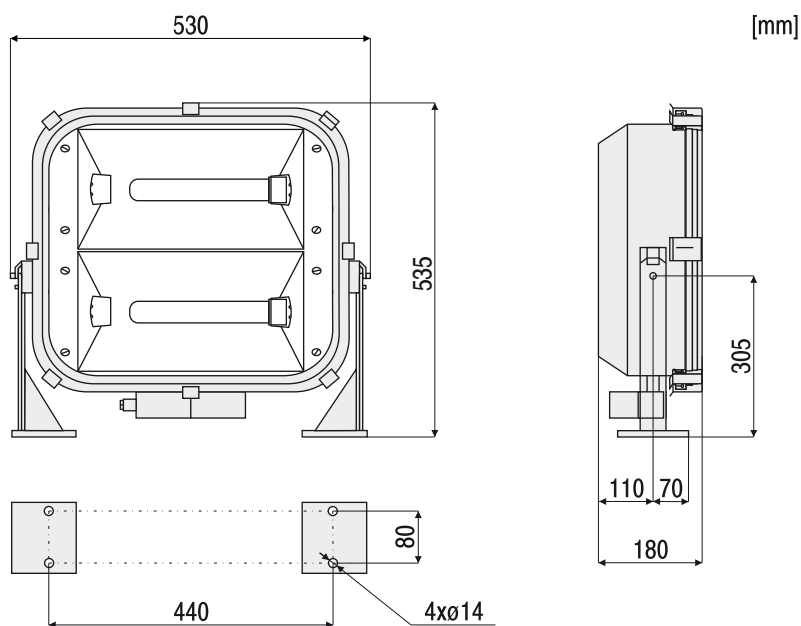

### OPTIONS

SC-Glands for screen cable 